

Date: _____

For: File Resubmit
 Approval Other _____

PO No.: _____

Architect: _____

GC: _____

Engr: _____

Mech: _____

Rep: _____
 (Company) _____

(Project Manager)



LVN241HV4
 Multi F Vertical Air Handling Unit
 24,000 Btu/h Indoor Unit



Performance:

Nominal Cooling Capacity (Btu/h)	24,000
Nominal Heating Capacity (Btu/h)	27,000

Cooling Nominal Test Conditions: Indoor: 80°F DB/67°F WB Outdoor: 95°F DB/75°F WB
 Heating Nominal Test Conditions: Indoor: 70°F DB/60°F WB Outdoor: 47°F DB/43°F WB

Electrical:

Power Supply (V ¹ /Hz/Ø)	208-230 / 60 / 1
Rated Amps (A)	1.1

Piping:

Installed Liquid Pipe (in., O.D.)	Ø1/4
Installed Vapor Pipe (in., O.D.)	Ø1/2
Liquid Connection (in., O.D.)	Ø3/8
Vapor Connection (in., O.D.)	Ø5/8
Drain (In, ID)	3/4 FPT
Temperature Sensor	Thermistor

Standard Features:

- Filter Rack for Field Supplied Air Filter (16 x 20 x 1 inch)

Controls Features:

- W2 terminal connection
- Hot start
- Self diagnostics
- Soft dry (dehumidification)
- Weekly schedule
- Controller sold separately
- Inverter (variable speed fan)
- Group control
- Sleep mode
- Timer (on/off)
- Integrated dry contact for 3rd party thermostat
- ECM fan provides constant airflow regardless of permitted ESP

Optional Accessories:

- Simple Controller - PREMT00U
- MultiSITE™ CRC1 Remote Controller - PREMTBVC0
- MultiSITE™ CRC1+ Remote Controller - PREMTBVC1
- Premium Remote Controller - PREMTA000
- Wireless Handheld Remote Controller - PQWRHQ0FDB²
- AC Smart 5 - PACS5A000
- ACP 5 - PACP5A000
- LonWorks Gateway - PLNWKB100
- RS3 Remote Controller- PREMTB100
- Aux Heater Relay Kit- PRARHO
- Dry Contact Unit (1 contact, 24 VAC external power) - PDRYCB100
- Dry Contact Unit (2 setpoint) - PDRYCB400
- Remote Button Temperature Sensor - ZRTBS01
- 3 kW Electric Heater - ANEH033B1¹¹
- Wi-Fi Module - PWFMD200
- Downflow Kit - PNDFJ0

For a complete list of available accessories, contact your LG representative.

For continual product development, LG reserves the right to change specifications without notice.

© LG Electronics Canada, Inc., North York, ON. All rights reserved. "LG Life's Good" is a registered trademark of LG Corp. /www.lgdfs.ca

Operating Range:

Cooling (°F WB)	57-77
Heating (°F DB)	59-81

Unit Data:

Refrigerant Type	R410A
Refrigerant Control	EEV
Sound Pressure ³ H/M/L	36 / 34 / 30
Net Unit Weight (lbs)	123.5
Shipping Weight (lbs)	135.1

Fan:

Type	Sirocco
Quantity	1
Motor/Drive	ECM (Electronically Commutated Motor)/Direct
Airflow Rate H/M/L (CFM)	710 / 640 / 480
Maximum External Static Pressure (in wg)	0.7

Notes:

1. Acceptable operating voltage is 187V-253V.
2. Wireless handheld remote controller requires an LG wired thermostat.
3. Sound Pressure levels are tested in an anechoic chamber under ISO Standard 1996.
4. See Engineering Manual for sensible and latent capacities.
5. All power/communication cable to be minimum 14 AWG, 4-conductor, stranded, shielded or unshielded, and must comply with applicable local and national code. If shielded, must be grounded to the chassis at ODU only.
6. Power wiring cable size must comply with the applicable local and national codes.
7. This unit comes with a dry helium charge.
8. Corresponding refrigerant piping length is in accordance with standard length of each outdoor unit and the level difference is 0 ft. All capacities are net with a combination ratio between 95 – 105%.
9. Must follow installation instructions in the applicable LG installation manual.
10. Includes socket adapters for refrigerant pipe connections.
11. Electric heater accessory available in 3kW, 5kW, 8kW, and 10kW capacities. Refer to the engineering manual for details.
12. Controller not included.



LVN241HV4
Multi F Vertical Air Handling Unit
24,000 Btu/h Indoor Unit



Tag #:

Date:

PO No.:

Factory Configurations

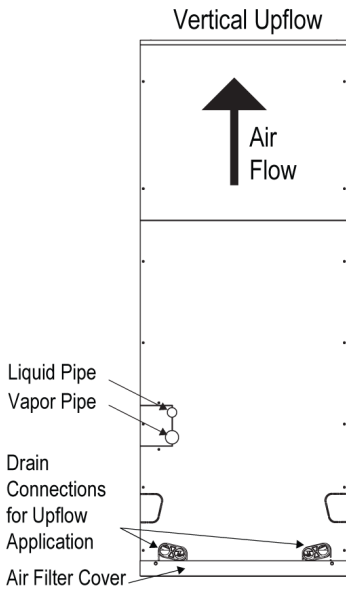

Field Configurations

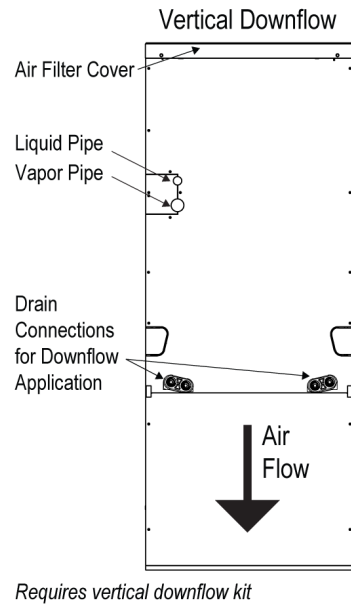

Horizontal Left

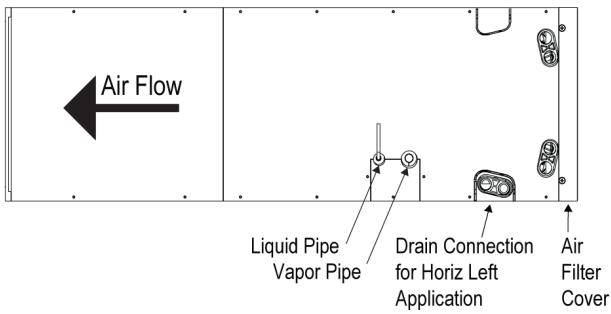

Horizontal Right

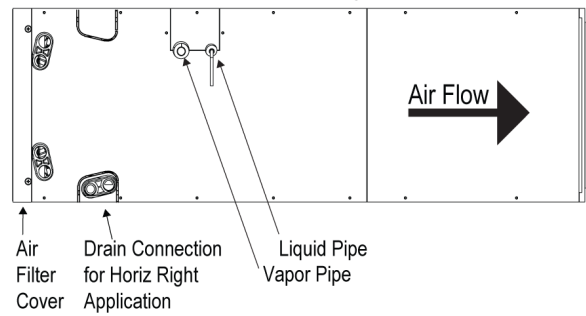

Job Name/Location:

LVN241HV4
Multi F Vertical Air Handling Unit
24,000 Btu/h Indoor Unit

Tag #: _____

Date: _____

PO No.: _____

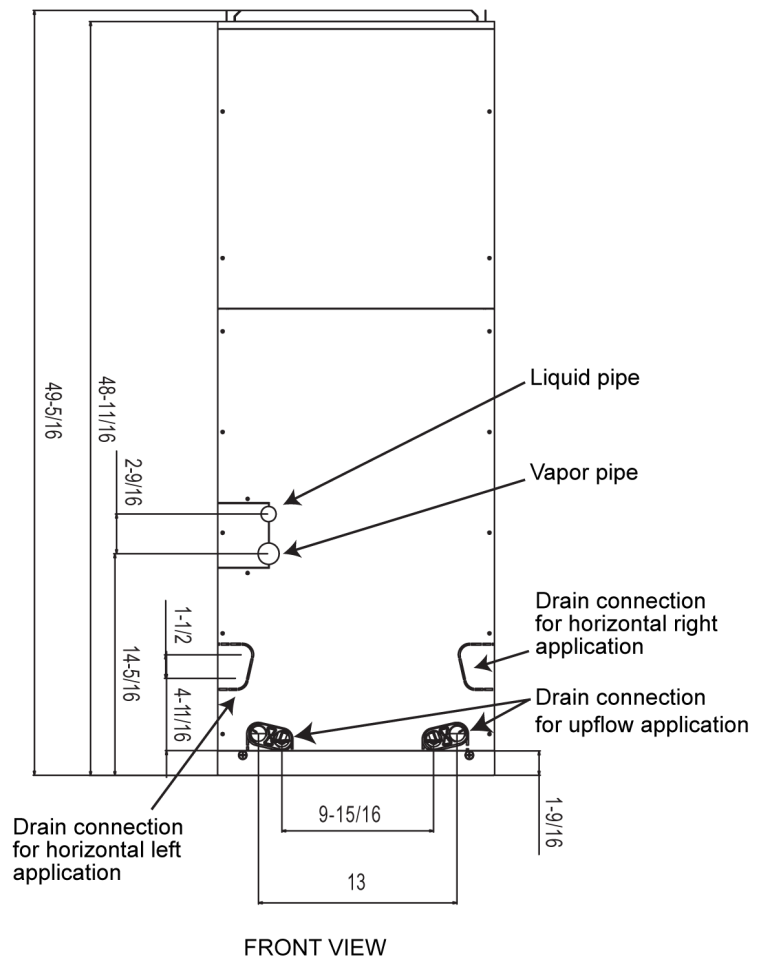
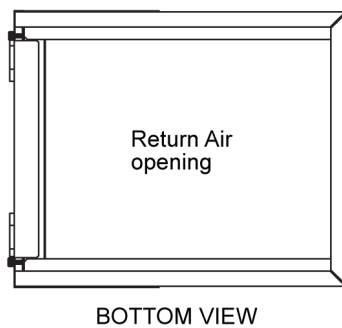
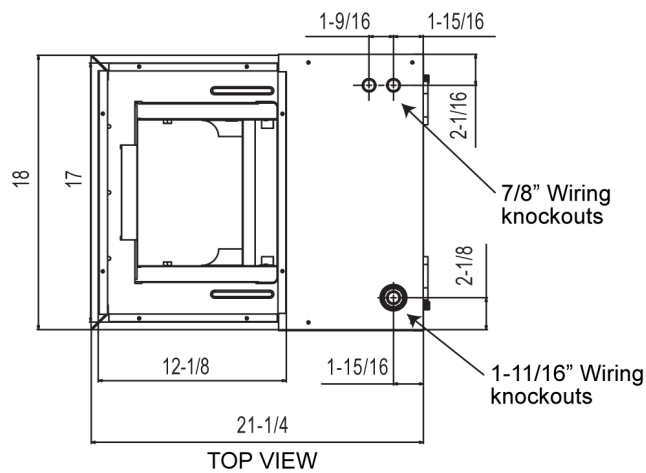
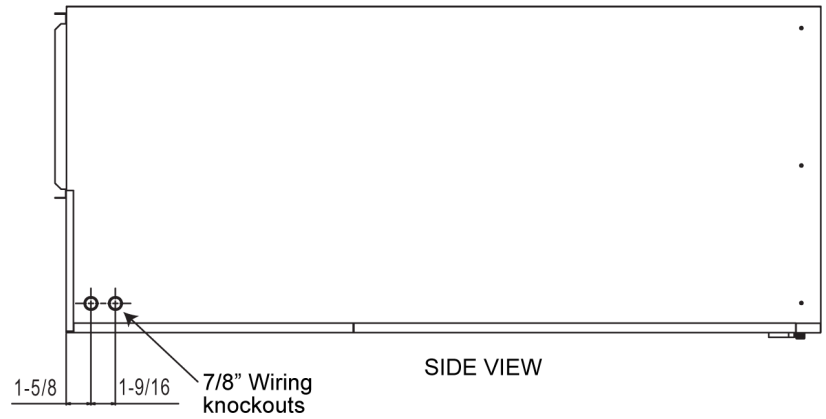
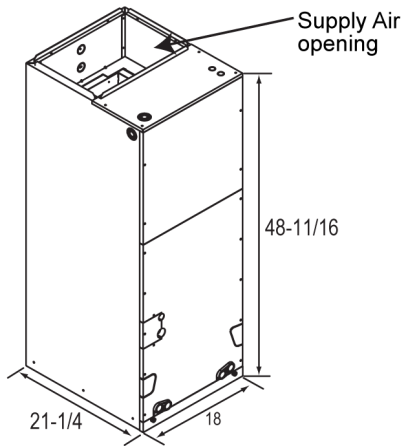

Unit: inches
Note: All measurements have a tolerance of $\pm 1/4$ in.